

## **PRODUCT INFORMATION**

Rotavirus vaccine – live attenuated oral

### **NAME OF THE MEDICINE**

*ROTARIX*

Human rotavirus (live attenuated oral vaccine) oral liquid

### **DESCRIPTION**

*ROTARIX* is a liquid suspension of the live attenuated RIX4414 strain of human rotavirus of the G1P[8] type for use in the prevention of rotavirus gastro-enteritis. The virus strain derived from the 89-12 strain is obtained by propagation on a well-characterised Vero cell line.

*ROTARIX* is presented as a clear, colourless liquid, free of visible particles, for ORAL administration only.

Each 1.5 mL dose of the vaccine contains not less than  $10^{6.0}$  CCID<sub>50</sub> (cell culture infectious dose 50%) of the RIX 4414 strain of human rotavirus. The vaccine also contains sucrose, di-sodium adipate, Dulbecco's Modified Eagle Medium and sterile water.

The manufacture of this product includes exposure to bovine derived materials at the very early steps of the production process. No bovine materials are used in routine production. No evidence exists that any case of vCJD (considered to be the human form of bovine spongiform encephalopathy) has resulted from the administration of any vaccine product.

Porcine Circovirus type 1 (PCV-1) material has been detected in *ROTARIX* vaccine. PCV-1 is not known to cause disease in animals and is not known to infect or cause disease in humans. There is no evidence that the presence of PCV-1 poses a safety risk.

### **PHARMACOLOGY**

Rotavirus is likely to affect all children up to the age of five years of age. The peak incidence of rotavirus gastro-enteritis is between 6-24 months of age. Dehydration from rotavirus gastro-enteritis can lead to hospitalisation, which is most common in children under 2 years of age.

#### **Mechanism of Action**

The immunologic mechanism by which *ROTARIX* protects against rotavirus gastro-enteritis is not entirely understood. A relationship between antibody responses to rotavirus vaccination and protection against rotavirus gastro-enteritis has not been established. *ROTARIX*, which is derived from the most

common human rotavirus type G1P[8], has been demonstrated to induce protective immunity against both the G1P[8] type, and also against other non-G1 prevalent strains (See Clinical Trials).

## **CLINICAL TRIALS**

### **Protective efficacy of the ROTARIX lyophilised formulation**

In clinical trials, efficacy was demonstrated against gastro-enteritis due to rotavirus of the most common genotypes G1P[8], G2P[4], G3P[8], G4P[8] and G9P[8] and against uncommon rotavirus genotypes G8P[4](severe gastro-enteritis) and G12P[6] (any gastro-enteritis). All of these strains are circulating worldwide.

Clinical studies have been conducted in Europe, Latin America, Africa and Asia to evaluate the protective efficacy of *ROTARIX* against any and severe rotavirus gastro-enteritis in countries with different levels of burden of disease.

Severity of gastro-enteritis was defined according to two different criteria:

- the Vesikari 20-point scale, which evaluates the full clinical picture of rotavirus gastro-enteritis by taking into account the severity and duration of diarrhoea and vomiting, the severity of fever and dehydration as well as the need for treatment

or

- the clinical case definition based on World Health Organization (WHO) criteria for determination of degree of dehydration (A: no dehydration, B: some dehydration, C: severe dehydration).

In the Rotarix clinical studies, severe gastro-enteritis is being defined as a gastroenteritis episode requiring hospitalisation and/or re-hydration therapy (equivalent to the World Health Organisation plan B or C) in a medical facility with a score of 11 or greater on the Vesikari scale.

Protective efficacy has been shown to be higher against severe rotavirus gastroenteritis than rotavirus gastroenteritis of any severity.

#### *Protective efficacy in Europe:*

A clinical study performed in Europe evaluated *ROTARIX* given according to different European schedules (2, 3months; 2, 4 months; 3, 4 months; 3, 5 months) in 3,994 subjects (2646 subjects receiving *ROTARIX* and 1348 subjects receiving placebo). The first dose was given between 6 and 14 weeks of age and the second dose was administered 4 to 8 weeks later.

After two doses of *ROTARIX*, the protective vaccine efficacy observed during the first and second year of life and the two years combined is presented in Table 1.

**Table 1: Efficacy following two doses of ROTARIX persisting during the first and second year of life and the two years combined - European study**

	1 <sup>st</sup> Year of life <sup>3</sup>		2 <sup>nd</sup> Year of life <sup>4</sup>		1 <sup>st</sup> and 2 <sup>nd</sup> Year of life combined <sup>3</sup>	
	Efficacy (%)	95% CI <sup>2</sup>	Efficacy (%)	95% CI <sup>2</sup>	Efficacy (%)	95% CI <sup>2</sup>
<b>Any rotavirus gastro-enteritis</b>	87.1*	79.6;92.1	71.9*	61.2;79.8	78.9*	72.7;83.8
<b>Severe rotavirus gastro-enteritis<sup>1</sup></b>	95.8*	89.6;98.7	85.6*	75.8;91.9	90.4*	85.1;94.1
<b>Rotavirus gastro-enteritis requiring medical attention</b>	91.8*	84;96.3	76.2*	63.0;85.0	83.8*	76.8;88.9
<b>Hospitalisation due to rotavirus gastro-enteritis</b>	100*	81.8;100	92.2*	65.6;99.1	96.0*	83.8;99.5

1. Severe gastro-enteritis defined as a score  $\geq 11$  on the Vesikari scale  
2. CI: Confidence Interval  
3. ROTARIX N=2572, Placebo N= 1302 (§)  
4. ROTARIX N=2554, Placebo N= 1294 (§)  
(§) ATP cohort for efficacy  
\* Statistically significant ( $p < 0.05$ )

The type specific vaccine efficacy is presented in Table 2 below:

**Table 2: Efficacy of ROTARIX lyophilised formulation against any and severe rotavirus gastro-enteritis to common serotypes – European study**

Type	1 <sup>st</sup> Year of life				2 <sup>nd</sup> Year of life				1 <sup>st</sup> and 2 <sup>nd</sup> Year of life combined			
	All rotavirus gastro-enteritis		Severe rotavirus gastro-enteritis <sup>1</sup>		All rotavirus gastro-enteritis		Severe rotavirus gastro-enteritis <sup>1</sup>		All rotavirus gastro-enteritis		Severe rotavirus gastro-enteritis <sup>1</sup>	
	Efficacy <sup>2</sup>	95% CI <sup>3</sup>	Efficacy <sup>2</sup>	95% CI <sup>3</sup>	Efficacy <sup>2</sup>	95% CI <sup>3</sup>	Efficacy <sup>2</sup>	95% CI <sup>3</sup>	Efficacy <sup>2</sup>	95% CI <sup>3</sup>	Efficacy <sup>2</sup>	95% CI <sup>3</sup>
G1P[8]	95.6*	87.9; 98.8	96.4*	85.7; 99.6	82.7*	67.8; 91.3	96.5*	86.2; 99.6	89.5*	82.5; 94.1	96.4*	90.4; 99.1
G2P[4]	62.0	-124.4; 94.4	74.7	-386.2; 99.6	57.1*	-3.7; 82.6	89.9*	9.4; 99.8	58.3*	10.1; 81.0	85.5*	24.0; 98.5
G3P[8]	89.9*	9.5; 99.8	100.0*	44.8; 100.0	79.7*	-23.8; 98.1	83.1	-110.3; 99.7	84.8*	41.0; 97.3	93.7*	52.8; 99.9
G4P[8]	88.3*	57.5; 97.9	100.0*	64.9; 100.0	69.6	-56.2; 95.3	87.3*	-28.0; 99.7	83.1*	55.6; 94.5	95.4*	68.3; 99.9
G9P[8]	75.6*	51.1; 88.5	94.7*	77.9; 99.4	70.5*	50.7; 82.8	76.8*	50.8; 89.7	72.5*	58.6; 82.0	84.7*	71.0; 92.4
Strains with P[8] genotype	88.2*	80.8; 93.0	96.5*	90.6; 99.1	75.7*	65.0; 83.4	87.5*	77.8; 93.4	81.8*	75.8; 86.5	91.9*	86.8; 95.3

1. Severe gastro-enteritis defined as a score  $\geq 11$  on the Vesikari scale  
2. Efficacy (%): Vaccine efficacy defined as 1-stratified Poisson rate ratio  
3. CI: Confidence Interval  
\* Statistically significant ( $p < 0.05$ )

When the severity of rotavirus gastro-enteritis was scored using the 20-point Vesikari scale, vaccine efficacy during the first year of life progressively increased with increasing disease severity, reaching 100% (95% CI: 84.7;100) for Vesikari scores  $\geq 17$ .

*Between dose efficacy:*

Although ROTARIX is a 2-dose vaccine, efficacy has been observed as from the first dose. In Europe, vaccine efficacy against rotavirus gastro-enteritis of any severity from dose 1 up to dose 2 was 89.8% (95% CI: 8.9; 99.8).

*Protective efficacy in Latin America:*

A clinical study performed in Latin America evaluated *ROTARIX* in more than 20,000 subjects. The first dose was given between 6 and 12 weeks of age and the second dose was administered 4 to 8 weeks later. After two doses of *ROTARIX*, the protective vaccine efficacy against severe rotavirus gastro-enteritis requiring hospitalisation and/or rehydration therapy in a medical facility was 84.7% (95% CI: 71.7; 92.4). Protective efficacy of *ROTARIX* was maintained during the second year of life with a vaccine efficacy against severe rotavirus gastro-enteritis of 79.0% (95% CI: 66.4; 87.4).

*Protective efficacy in Africa:*

A clinical study performed in Africa in more than 4,900 subjects evaluated *ROTARIX* given at approximately 10 and 14 weeks of age (2 doses) or 6, 10 and 14 weeks of age (3 doses). The vaccine efficacy against severe rotavirus gastro-enteritis (scored using the 20-point Vesikari scale) during the first year of life was 61.2% (95% CI: 44.0;73.2). The study was not powered to evaluate a difference in vaccine efficacy between the 2- and 3-dose regimens.

The protective vaccine efficacy observed against any and severe rotavirus gastro-enteritis is presented in Table 3.

**Table 3: Efficacy of *ROTARIX* to common serotypes against any and severe rotavirus gastro-enteritis – African study**

Strain	Any rotavirus gastro-enteritis (1 <sup>st</sup> year of life - Pooled results) Rotarix N=2,974 Placebo N=1,443	Severe rotavirus gastro-enteritis (1 <sup>st</sup> year of life - Pooled results) Rotarix N=2,974 Placebo N=1,443
	Efficacy (%) [95% CI]	Efficacy (%) [95% CI]
All Serotypes	53.4* [42.1;62.6]	61.2* [44.0;73.2]
G1P[8]	68.3* [53.6;78.5]	56.6* [11.8;78.8]
G2P[4]	49.3* [4.6;73.0]	83.8* [9.6;98.4]
G3P[8]	43.4 [<0;83.7]	51.5 [<0;96.5]
G8P[4]	38.7 [<0;67.8]	63.6* [5.9;86.5]
G9P[8]	41.8 [<0;72.3]	56.9 [<0;85.5]
G12P[6]	48.0* [9.7;70.0]	55.5 [<0; 82.2]
Strains with P[4] genotype	39.3* [7.7;59.9]	70.9* [37.5;87.0]
Strains with P[6] genotype	46.6* [9.4;68.4]	55.2 [<0;81.3]
Strains with P[8] genotype	61.0* [47.3;71.2]	59.1* [32.8;75.3]

\* Statistically significant (p < 0.05)

### Sustained efficacy up to 3 years of age in Asia

A clinical study conducted in Asia (Hong Kong, Singapore and Taiwan) in more than 10000 subjects evaluated Rotarix given according to different schedules (2, 4 months of age; 3, 4 months of age).

After two doses of Rotarix, the protective vaccine efficacy observed up to 3 years of age is presented in table 4.

**Table 4: Efficacy of ROTARIX to common serotypes against any and severe rotavirus gastro-enteritis - Asian study**

	Efficacy up to 2 years of age Rotarix N= 5263(§) Placebo N= 5256(§)	Efficacy up to 3 years of age Rotarix N= 5263(§) Placebo N= 5256(§)
Vaccine efficacy (%) against severe rotavirus gastro-enteritis (95% CI)		
Type	Severe <sup>†</sup>	Severe <sup>†</sup>
G1P[8]	100.0 (80.8;100.0)	100.0 (84.8;100.0)
G2P[4]	100.0* (<0;100.0)	100.0* (<0;100.0)
G3P[8]	94.5 (64.9;99.9)	95.2 (70.4;99.9)
G9P[8]	91.7 (43.8;99.8)	91.7 (43.8;99.8)
Strains with P[8] genotype	95.8 (83.8;99.5)	96.6 (87.0;99.6)
Circulating rotavirus strains	96.1 (85.1;99.5)	96.9 (88.3;99.6)
Vaccine efficacy (%) against rotavirus gastro-enteritis requiring hospitalisation and/or rehydration therapy in a medical facility [95% CI]		
Circulating rotavirus strains	94.2 (82.2;98.8)	95.5 (86.4;99.1)

<sup>†</sup> Severe gastro-enteritis was defined as a score >11 on the Vesikari scale

(§) ATP cohort for efficacy. This includes all subjects from the ATP cohort for safety who have entered into the concerned efficacy follow-up period

\* Not statistically significant ( $p \geq 0.05$ ). These data should be interpreted with caution.

*ROTARIX* does not protect against non-rotaviral gastro-enteritis, or against diarrhoea due to other infectious and non-infectious causes.

### **Effectiveness**

In observational studies, vaccine effectiveness was demonstrated against severe gastro-enteritis leading to hospitalisation due to rotavirus of common genotypes G1P[8], G2P[4], G3P[8] and G9P[8] as well as the less common rotavirus genotype G9P[4] and G9P[6]. All of these strains are circulating worldwide.

Table 5 shows the results of several matched case-control studies conducted to evaluate the effectiveness of ROTARIX against severe rotavirus gastro-enteritis leading to hospitalisation.

**Table 5: Effectiveness against severe rotavirus gastro-enteritis leading to hospitalisation**

Countries	Age	N (cases/ controls)	Effectiveness after 2 doses RV hospitalisation	
			Strain	Effectiveness (%) [95% CI]
<b>High Income Countries</b>				
Belgium	< 4 yrs	160/198	All G1P[8] G2P[4]	90 [81;95] 95 [78;99] 85 [64;94]
	3-11 m		All G2P[4]	91 [75;97] 83 [11;96]
Taiwan	< 3 yrs	275/1623	All G1P[8]	92 [75;98] 95 [69;100]
US	< 2 yrs	85/1062	All G1P[8] G2P[4]	85 [73;92] 88 [68;95] 88 [68;95]
	8-11 m		All	89 [48;98]
US	< 5 yrs	74/255	G3P[8]	68 [34;85]
<b>Middle Income Countries</b>				
Bolivia	< 3 yrs	300/974	All G9P[8] G3P[8] G2P[4] G9P[6]	77 [65;84] 85 [69;93] 93 [70;98] 69 [14;89] 87 [19;98]
	6-11 m		All G9P[8]	77 [51;89] 90 [65;97]
Brazil	< 2 yrs	115/1481	All G1P[8] G2P[4]	72 [44;85] 89 [78;95] 76 [64;84]
Brazil	< 3 yrs	249/249	All G2P[4]	76 [58;86] 75 [57;86]
	3-11 m		All G2P[4]	96 [68;99] 95 [66;99]
El Salvador	< 2 yrs	251/770	All	76 [64;84]*
	6-11 m			83 [68;91]
Mexico	< 2 yrs	9/17	G9P[4]	94 [16;100]
<b>Low Income Countries</b>				
Malawi	< 2 yrs	81/234	All	63 [23;83]

\* In subjects who did not receive the full course of vaccination, the effectiveness after one dose was 51 % (95% CI: 26;67).  
yr(s): year(s)  
m: months

### ***Impact on hospitalisation<sup>§</sup>***

In a retrospective database study in Belgium conducted in children 5 years of age and younger, the direct and indirect impact of ROTARIX vaccination on rotavirus-related hospitalisation ranged from 64% (95% CI: 49;76) to 80% (95% CI: 77;83) two years after vaccine introduction. Similar studies in Brazil, Australia and El Salvador showed a reduction of 45 to 88%. In addition, two impact studies on all-cause diarrhoea hospitalisation conducted in Latin America showed a reduction of 38 to 40% four years after vaccine introduction.

### ***Impact on mortality<sup>§</sup>***

Impact studies with ROTARIX conducted in Panama, Brazil and Mexico showed a decrease in all cause diarrhoea mortality ranging from 22% to 56% in children less than 5 years of age, within 2 to 3 years after vaccine introduction.

<sup>§</sup>NOTE: Impact studies are meant to establish a temporal relationship but not a causal relationship between the disease and vaccination.

### ***Immune response in preterm infants***

In a clinical study conducted in preterm infants (N=1009; with gestational age of 27 to 36 weeks) 670 subjects received the lyophilised formulation and the immunogenicity of *ROTARIX* was assessed in a subset of 147. *ROTARIX* was immunogenic; 85.7% of subjects achieved serum anti-rotavirus IgA antibody titres  $\geq 20$ U/ml (by ELISA) one month after the second dose of vaccine.

### ***Immunogenicity of the ROTARIX liquid formulation***

The immune response observed after 2 doses of *ROTARIX* liquid formulation was comparable to the immune response observed after 2 doses of *ROTARIX* lyophilised formulation in terms of anti-rotavirus IgA antibody seroconversions and geometric mean concentrations.

## **INDICATIONS**

*ROTARIX* is indicated for the prevention of rotavirus gastroenteritis (see Clinical Trials).

## **CONTRAINDICATIONS**

*ROTARIX* should not be administered to subjects with known hypersensitivity to any components of the vaccine (see DESCRIPTION), or to subjects having shown signs of hypersensitivity after previous administration of rotavirus vaccines.

*ROTARIX* should not be administered to subjects with any history of chronic gastrointestinal disease including any uncorrected congenital malformation (such as Meckel's diverticulum) of the gastrointestinal tract.

Subjects with history of intussusception.

Subjects with Severe Combined Immunodeficiency (SCID) disorder (see ADVERSE REACTIONS).

As with other vaccines, administration of *ROTARIX* should be postponed in subjects suffering from acute severe febrile illness. The presence of a minor infection, such as a cold, is not a contraindication for immunisation.

## **PRECAUTIONS**

### ***ROTARIX* SHOULD UNDER NO CIRCUMSTANCES BE INJECTED.**

It is good clinical practice that vaccination should be preceded by a review of the medical history (especially with regard to previous vaccination and possible occurrence of undesirable events) and a clinical examination.

The administration of *ROTARIX* should be postponed in subjects suffering from diarrhoea or vomiting.

Administration of *ROTARIX* may be considered with caution in infants with gastrointestinal illnesses, when, in the opinion of the physician, the risk of rotavirus infection by withholding the vaccine entails a greater risk to the infant. No safety or efficacy data are available for the administration of *ROTARIX* to infants with gastrointestinal illnesses.

Administration of *ROTARIX* in immunosuppressed infants, including infants on immunosuppressive therapy, should be based on careful consideration of potential benefits and risks.

The risk of intussusception has been evaluated in a large safety trial (including 63,225 infants) conducted in Latin America and Finland. No increased risk of intussusception was observed in this clinical trial following administration of *ROTARIX* when compared with placebo (see ADVERSE REACTIONS).

Data from post-marketing studies indicate an increased incidence of intussusception shortly after the administration of the first dose and second dose of *ROTARIX* (See ADVERSE REACTIONS).

Whether vaccination with *ROTARIX* affects the overall risk of intussusception has not been established. The overall incidence of intussusception remains rare.



Therefore, healthcare professionals should follow-up on any symptoms suggestive of intussusception after rotavirus vaccine administration. These symptoms can include, severe abdominal pain or distress, persistent vomiting, bloody stools, palpable abdominal mass, abdominal bloating and/or high fever.

Parents/guardians should be advised to seek medical advice promptly where these signs/symptoms are evident.

*ROTARIX* should not be administered in subjects with a predisposition for intussusception (see CONTRAINDICATIONS).

Excretion of the vaccine virus in the stools occurs after vaccination and lasts for 10 days on average with peak excretion around the 7th day. Viral antigen particles detected by ELISA were found in 50% of stools after the first dose and 4% of stools after the second dose. When these stools were tested for the presence of live vaccine strain, 17% were positive. In two comparative controlled trials, vaccine shedding after vaccination with *ROTARIX* liquid formulation was comparable to that observed after vaccination with *ROTARIX* lyophilised formulation.

In clinical trials, cases of transmission of excreted vaccine virus to seronegative contacts of vaccinees have been observed without causing any clinical symptoms.

There is a potential risk for transmission to non-vaccinated contacts. Therefore *ROTARIX* should be administered with caution to infants with close contacts who are immunodeficient, such as household members with malignancies or who are otherwise immunocompromised or receiving immunosuppressive therapy. Contacts of recent vaccinees should be advised to observe personal hygiene (e.g. washing their hands when changing children's nappies).

As with any vaccine, a protective immune response may not be elicited in all vaccinees (see CLINICAL TRIALS).

The extent of protection that *ROTARIX* might provide against rotavirus strains that have not been circulating in clinical trials is currently unknown (see CLINICAL TRIALS).

*ROTARIX* does not protect against gastro-enteritis due to pathogens other than rotavirus.

### **Carcinogenicity and Mutagenicity**

*ROTARIX* has not been evaluated for carcinogenicity or mutagenicity.

### **Impairment of Fertility**

*ROTARIX* has not been evaluated for its potential to impair fertility.

**Genotoxicity**

*ROTARIX* has not been evaluated for genotoxicity.

**Use in Pregnancy (Category B2):**

*ROTARIX* is not intended for use in adolescents or adults. Thus human data on use during pregnancy are not available and animal reproduction studies have not been performed.

**Use in Lactation:**

*ROTARIX* is not intended for use in adolescents or adults. Thus human data on use during lactation are not available.

Based on evidence generated in clinical trials, breast-feeding does not reduce the protection against rotavirus gastro-enteritis afforded by *ROTARIX*. Therefore, breast-feeding may be continued during the vaccination schedule.

**Paediatric Use**

*ROTARIX* is intended for use in infants in the first six months of life. *ROTARIX* should not be administered to children older than 24 weeks of age as safety has not been demonstrated, particularly in relation to risk of intussusception.

**Use in the Elderly**

*ROTARIX* is not intended for use in the elderly. Thus human data on use in the elderly are not available.

**Effects on laboratory tests**

*ROTARIX* has not been evaluated for effects on laboratory tests.

**INTERACTIONS WITH OTHER MEDICINES**

Co-administration studies have demonstrated that *ROTARIX* can be given concomitantly with any of the following administered either as monovalent or as combination vaccines: diphtheria-tetanus-acellular pertussis vaccine (DTPa), *Haemophilus influenzae* type b vaccine (Hib), inactivated polio vaccine (IPV), hepatitis B vaccine (HBV), hexavalent vaccines DTPa-HBV-IPV/Hib, pneumococcal conjugate vaccine and meningococcal serogroup C conjugate vaccine. The studies demonstrated that the immune responses and the safety profiles of the administered vaccines were unaffected.

Clinical studies, involving more than 2,000 subjects, were performed where *ROTARIX* and oral polio vaccine (OPV) were administered two weeks apart. The immune response to *ROTARIX* and OPV was unaffected. In three immunogenicity studies, involving approximately 1,200 subjects, *ROTARIX* was concomitantly administered with OPV. The immune response to OPV, as well as the response to *ROTARIX* after the second dose, were unaffected. *ROTARIX* can be concomitantly administered with

OPV if this is in accordance with local recommendations. In the absence of local recommendations, an interval of two weeks between the administration of OPV and *ROTARIX* should be respected.

Although antibodies to rotavirus may be detected in breast milk, the available data show no reduction in efficacy when *ROTARIX* is administered to breast-fed infants.

### **Effects on laboratory tests**

*ROTARIX* has not been evaluated for effects on laboratory tests.

## **ADVERSE EFFECTS**

### **Clinical Trial Experience**

The safety profile presented below is based on data from clinical trials conducted with either the lyophilised or the liquid formulation of *ROTARIX*.

In a total of four clinical trials, approximately 3,800 doses of *ROTARIX* liquid formulation were administered to approximately 1,930 infants. These trials have shown that the safety and reactogenicity profile of the liquid formulation is comparable to the lyophilised formulation.

A total of twenty-three clinical trials involved the administration of more than 106,000 doses of *ROTARIX* to approximately 51,000 infants. Twenty of 23 are placebo-controlled clinical studies. Serious adverse events (SAEs) were collected for all 20 placebo-controlled studies, and solicited and unsolicited adverse events were collected in 17 of 20 placebo-controlled studies. In these 17 placebo-controlled trials *ROTARIX* was administered either alone or concurrently with routine paediatric vaccines.

*ROTARIX* is generally well tolerated.

### **Solicited adverse events**

In the 17 placebo-controlled clinical trials, the solicited events collected within 8 days of vaccination were diarrhoea, vomiting, loss of appetite, fever, irritability and cough/runny nose. Irrespective of whether *ROTARIX* was administered with or without other paediatric vaccines no significant difference in frequency and severity of these solicited adverse events was observed between the group receiving *ROTARIX* and the group receiving placebo. No increase in the incidence or severity of these events was seen with the second dose.

### **Unsolicited Adverse Events**

In the 17 placebo-controlled clinical trials the unsolicited adverse reaction profile observed in the subjects receiving *ROTARIX* was comparable to the subjects receiving the same paediatric vaccines and placebo (Total Number of subjects in *ROTARIX* group = 10,212 in 17 studies; placebo group =

3,840). Nevertheless, the following vaccine related unsolicited adverse event incidences were observed within 31 days following vaccination with *ROTARIX*: irritability, flatulence, abdominal pain, dermatitis.

### Serious Adverse Events

In 20 placebo-controlled clinical trials, the frequencies and severity of the serious adverse events within 31 days post vaccination with *ROTARIX* were compared between *ROTARIX* and placebo recipients. Following serious adverse events were observed in *ROTARIX* group compared to placebo group regardless of causality (Table 6).

**Table 6: Subjects reporting Serious Adverse reactions per system organ class and frequency regardless of causality within 31 days post vaccination period – 20 pooled studies (Total Vaccinated Cohort)**

		<i>ROTARIX</i> N=51620	Placebo N=42933
System Organ Class	Preferred term	Incidence in the <i>ROTARIX</i> group; n(n%)	Incidence in the placebo group; n(n%)
	At least one symptom	1003 (1.94%)	905 (2.11%)
Blood and lymphatic system	All symptoms	9	9
	Idiopathic thrombocytopenic purpura	1	0
Congenital, familial and genetic	All symptoms	10	6
	Gastrointestinal malformation	1	0
Gastrointestinal disorders	All symptoms	50 (0.09%)	65 (0.15%)
	diarrhoea	15 (0.03%)	27 (0.06%)
	abdominal pain	3	1
	constipation	1	4
	frequent bowel movement	1	0
	2	0	
	11 (0.02%)	7 (0.02%)	
General	intussusceptions	4	9
	vomiting		
Infections and infestations	All symptoms	24	22
	pyrexia	19 (0.04%)	14 (0.03%)
Metabolism and nutrition	respiratory tract infections (all symptoms)	868 (1.6%)	819 (1.9%)
	bronchiolitis	223 (0.43%)	174 (0.41%)
	bronchitis	36 (0.07%)	18 (0.04%)
	bronchopneumonia	44 (0.09%)	36 (0.08%)
	gastroenteritis	109 (0.21%)	146 (0.34%)
	Kawasaki disease*	18 (0.03%)	9 (0.02%)
	pneumonia	158 (0.31%)	136 (0.32%)
Nervous system disorders	All symptoms	28	30
	anorexia	5 (0.01%)	0
	dehydration	12	23
	weight gain poor	1	0
Respiratory, thoracic and mediastinal disorders	All symptoms	31	27
	convulsion	14 (0.03%)	10 (0.02%)
	hypotonic-hyporesponsive episode	1	0
	syncope - vasovagal	1	0
Respiratory, thoracic and mediastinal disorders	All symptoms	92	69
	apnoea	1	0
	asthma	10 (0.02%)	4 (0.01%)
	bronchitis chronic	14 (0.03%)	12 (0.03%)
	bronchospasm	32 (0.06%)	29 (0.05%)

Skin and subcutaneous tissue	All symptoms	15	9
	urticaria	1	0
	rash	1	0
	eczema	3	0
	dermatitis atopic	6	4

\*events during the entire study period

The risk of intussusception has been evaluated in a large safety trial conducted in Latin America and Finland where 63,225 subjects were enrolled. This trial gave evidence of no increased risk of intussusception in the *ROTARIX* group when compared with the placebo group as shown in the table below.

**Table 7: Confirmed cases of intussusception in recipients of *ROTARIX* lyophilised vaccine as compared with placebo recipients (Rota-023)**

	<i>ROTARIX</i>	Placebo	Relative risk (95% CI)
Intussusception within 31 days after administration of:	N = 31,673	N = 31,552	
First dose	1	2	0.50 (0.07; 3.80)
Second dose	5	5	0.99 (0.31; 3.21)
Intussusception up to one year of age	N=10,159	N=10,010	
First dose up to one year of age	4	14	0.28 (0.10; 0.81)
CI: confidence interval			

In a clinical study performed in Africa (See Clinical Trials), the safety profile was similar in all three groups. There was no statistical difference between groups for the percentage of subjects with serious adverse events and adverse events/serious adverse events leading to drop out. There were a total of 126 fatal events (83 subjects (2.5%) in the HRV pooled group and 43 subjects (2.6%) in the placebo group), which was in line with the mortality rate existing in the same geographical region.

In a clinical study performed in Asia (See 'Clinical Trials') where more than 10,000 subjects were enrolled, there were no definite intussusception cases diagnosed within 31 days (Day 0 to Day 30) after any Rotarix or placebo dose.

The incidence of definite intussusception was 5.6 cases per 10,000 in Rotarix vaccinated children compared to 3.7 cases per 10,000 in Placebo group at 9-10 months of follow-up and 14.9 cases per 10,000 in Rotarix vaccinated children compared to 7.5 cases per 10,000 in Placebo group at 21-22 months of follow-up.

### **Safety in preterm infants**

In a clinical study, 1009 preterm infants were administered *ROTARIX* lyophilised formulation or placebo (198 were 27-30 weeks gestational age and 801 were 31-36 weeks gestational age). The first dose was administered from 6 weeks after birth. Serious adverse events were observed in 5.1% of recipients of *ROTARIX* as compared with 6.8% of placebo recipients. Similar rates of solicited and unsolicited

symptoms were observed in *ROTARIX* and placebo recipients. No cases of intussusception were reported.

### **Safety in infants with human immunodeficiency (HIV) infection**

In a clinical study, 100 infants with HIV infection were administered *ROTARIX* lyophilised formulation or placebo. The safety profile was similar between *ROTARIX* and placebo recipients.

### **Post-marketing data**

The following adverse events have been reported since market introduction of *ROTARIX*. Because these events are reported voluntarily from a population of uncertain size, it is not always possible to reliably estimate their frequency or establish a causal relationship to vaccination with *ROTARIX*.

#### *Gastrointestinal disorders:*

*Rare:* haematochezia

gastroenteritis with vaccine viral shedding in infants with Severe Combined Immunodeficiency (SCID) disorder

*Very rare:* intussusception (see Precautions)

A large post-marketing epidemiological safety study in Mexico, representing approximately 1,000,000 vaccinated infants evaluated cases of intussusception in the 31 day period after *ROTARIX* vaccination. Data indicated a small increased incidence of intussusception in the 31 day period (relative incidence 1.751, 95%CI 1.237;2.477, p=0.001) and this occurred primarily within the 7 days following the first dose. These observations were not seen following administration of the second dose.

A self controlled case series analysis was undertaken in infants immunised between July 2007 and June 2010 in Australia to evaluate cases of intussusception in the 21 day period following any vaccination with rotavirus vaccines. Results from this study indicate an increased relative risk of intussusception of 6.76 (95% CI 2.40 - 19.01, p<0.001) and 3.45 (95% CI 1.33 - 8.94, p=0.01) within 1-7 days and 8-21 days respectively following the first dose of *ROTARIX*. There was also some evidence of an elevated relative risk of intussusception of 2.84 (95% CI 1.10 – 7.34, p=0.03) 1-7 days following receipt of the second dose of *ROTARIX*.

Whether *ROTARIX* affects the overall risk of intussusception has not been established.

#### *Blood and lymphatic disorders:*

idiopathic thrombocytopenic purpura

*Vascular disorders:*

Kawasaki disease

## **DOSAGE AND ADMINISTRATION**

### **Dosage**

The vaccination course consists of two doses. The first dose should be given between 6 and 14 weeks of age. The interval between the two doses should not be less than 4 weeks. The vaccine course should be completed by the age of 24 weeks as safety has not been assessed in older children.

In clinical trials, spitting or regurgitation of the vaccine has rarely been observed and, under such circumstances, a replacement dose was not given. However, in the unlikely event that an infant spits out or regurgitates most of the vaccine dose, a single replacement dose may be given at the same vaccination visit.

It is strongly recommended that infants who receive a first dose of *ROTARIX* complete the 2-dose regimen with *ROTARIX*.

### **Administration**

*ROTARIX* is for ORAL use only.

*ROTARIX* SHOULD UNDER NO CIRCUMSTANCES BE INJECTED.

There are no restrictions on the infant's consumption of food or liquid, including breast milk, either before or after vaccination.

### **Instructions for use and handling**

The vaccine is presented as a clear, colourless liquid, free of visible particles, for ORAL administration only. The vaccine is ready to use (no reconstitution or dilution is required).

The vaccine is to be administered ORALLY without mixing with any other vaccines or solutions.

The vaccine should be inspected visually for any foreign particulate matter and/or abnormal physical appearance. In the event of either being observed, discard the vaccine.

Any unused vaccine or waste material should be disposed of in accordance with local requirements.

**Instructions for administration of the vaccine in oral applicator (syringe-type applicator with a plunger stopper):**

1. Remove the protective tip cap from the oral applicator.
2. This vaccine is for oral administration only. The child should be seated in a reclining position. Administer orally (i.e. into the child's mouth towards the inner cheek) the entire content of the oral applicator.
3. Do not inject.

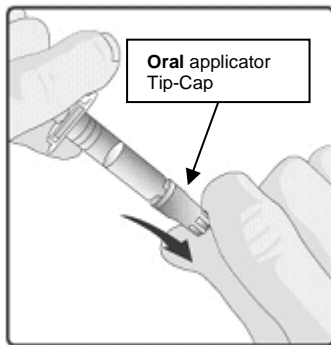

1. Remove the protective tip cap from the oral applicator.



2. This vaccine is for **oral administration only**. The child should be seated in a reclining position. Administer **orally** (i.e. into the child's mouth towards the inner cheek) the entire content of the **oral** applicator.

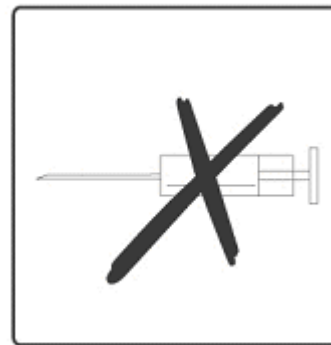

3. **Do not inject.**

Discard the empty oral applicator and tip cap according to local regulations.

**Instructions for administration of the vaccine in tube:**

Please read the instructions for use all the way through before starting to give the vaccine.

**A What you need to do before giving Rotarix**

- Check the expiry date.
- Check the tube has not been damaged nor is already open.
- Check the liquid is clear and colourless, without any particles in it.

If you notice anything abnormal, do not use the vaccine.

- This vaccine is given orally - straight from the tube.
- It is ready to use - you do not need to mix it with anything.

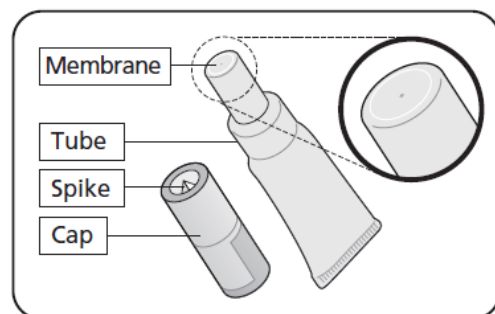

**B Get the tube ready**

**1. Pull off the cap**

- *Keep the cap – you need this to pierce the membrane.*
- *Hold the tube upright.*

**2. Repeatedly flick the top of the tube until it is clear of any liquid**

- Clear any liquid from the thinnest section of the tube by flicking just below the membrane.

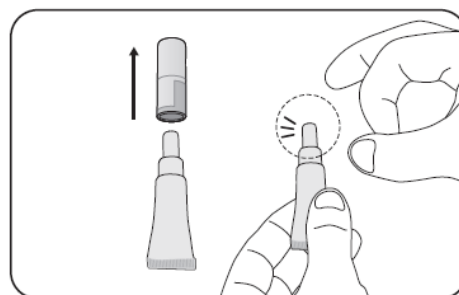



### 3. Position the cap to open the tube

- Keep the tube held upright.
- Hold the side of tube
- There is a small spike inside the top of the cap - in the centre.
- Turn the cap upside down (180°).

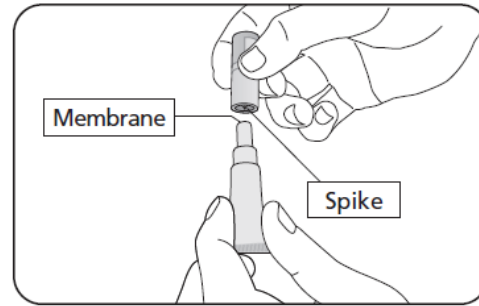

### 4. To open the tube

- You do not need to twist. Press the cap down to pierce the membrane.
- Then lift off the cap.

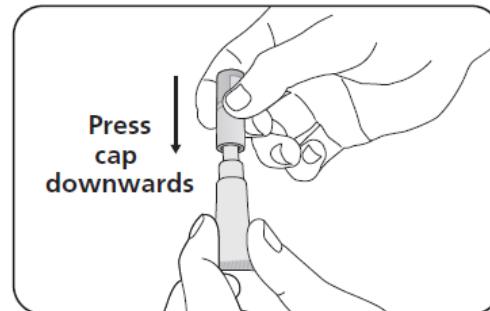

## C Check the tube has opened correctly

### 1. Check the membrane has been pierced

- There should be a hole at the top of the tube.

### 2. What to do if the membrane has not been pierced

- If the membrane has not been pierced return to section B and repeat steps 2, 3 and 4.

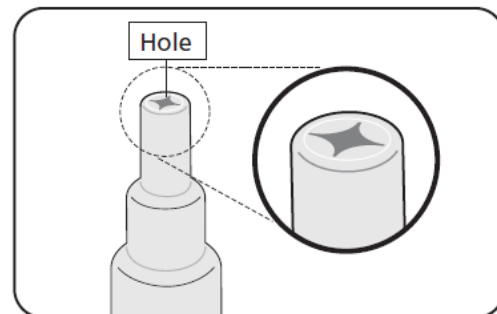

## D Give the vaccine

- Once the tube is open check the liquid is clear, without any particles in it.  
If you notice anything abnormal, do not use the vaccine.
- Give the vaccine straight away.

### 1. Position the child to give the vaccine

- Seat the child leaning slightly backwards.

### 2. Administer the vaccine

- Squeeze the liquid gently into the side of the child's mouth - towards the inside of their cheek.
- You may need to squeeze the tube a few times to get all of the vaccine out - it is okay if a drop remains in the tip of the tube.

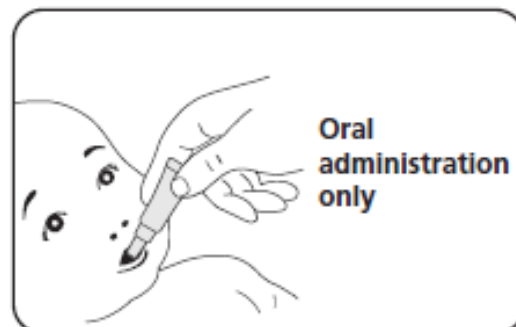

Discard the empty tube and cap according to local regulations.

## **OVERDOSAGE**

Some cases of overdose have been reported. In general, the adverse event profile reported in these cases was similar to that observed after administration of the recommended dose of Rotarix.

Contact Poisons Information Centre (131126) for advice regarding management of overdose.

## **PRESENTATION AND STORAGE CONDITIONS**

1.5 mL of oral suspension in an oral applicator (Type I, Ph. Eur.) with a plunger stopper (butyl rubber).

Pack sizes of 1, 5, 10, 25, 50 or 100

1.5 mL of oral suspension in a squeezable tube (LDPE) fitted with a membrane and a cap (polypropylene). Pack sizes of 1 or 10.

Not all presentations may be distributed in Australia.

Store at 2°C to 8°C (Refrigerate. Do not freeze). Store in the original package, in order to protect from light.

## **NAME AND ADDRESS OF THE SPONSOR**

GlaxoSmithKline Australia Pty Ltd,

Level 4

436 Johnston Street

Abbotsford, Victoria, 3067

## **DISTRIBUTED IN NEW ZEALAND BY:**

GlaxoSmithKline NZ Ltd

Private Bag 106600

Downtown Auckland 1143

New Zealand

## **POISON SCHEDULE OF THE DRUG**

Schedule 4 - Prescription Only Medicine

Date of first inclusion in the Australian Register of Therapeutic Goods (the ARTG): 27 August 2008

Date of recent amendment: 20 October 2017

*ROTARIX* is a registered trademark of the GlaxoSmithKline group of companies.

Version 14.0